



We Bear The Rolling World

FSQ



We Bear The Rolling World

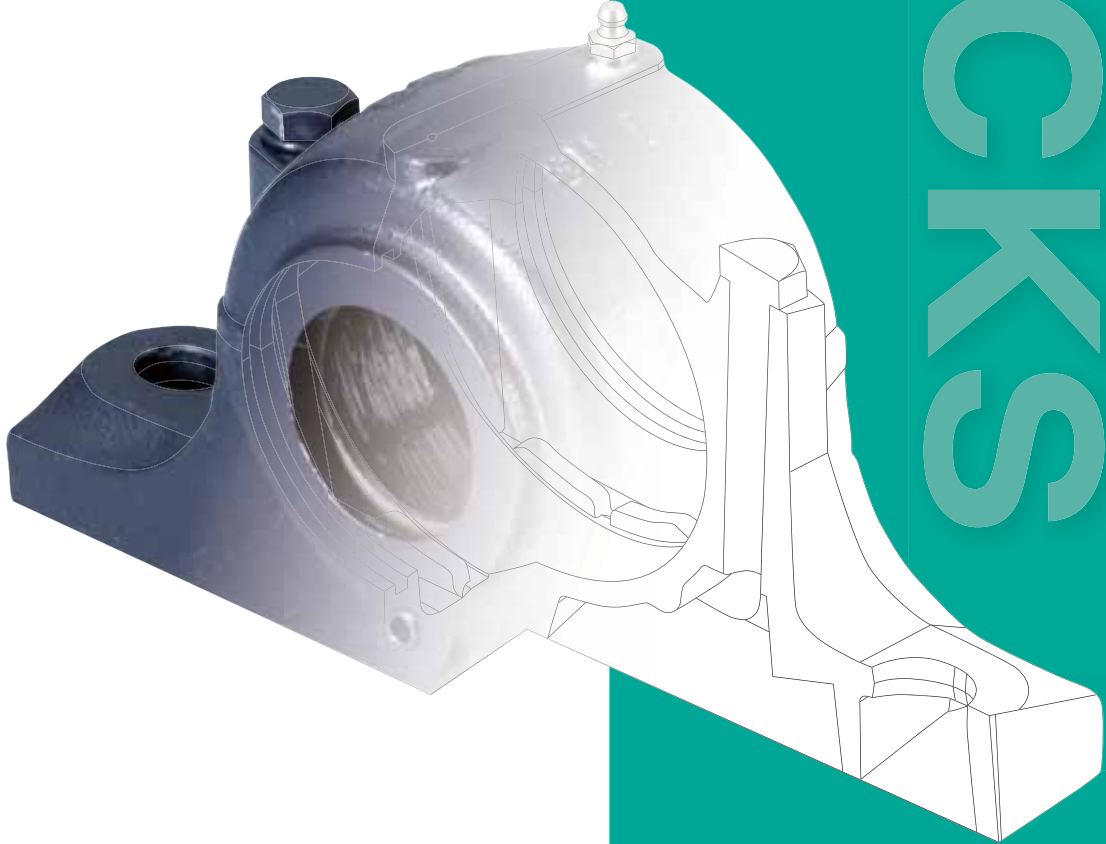

PLUMMIER
BLOCKS

プランマ ブロック

価格表

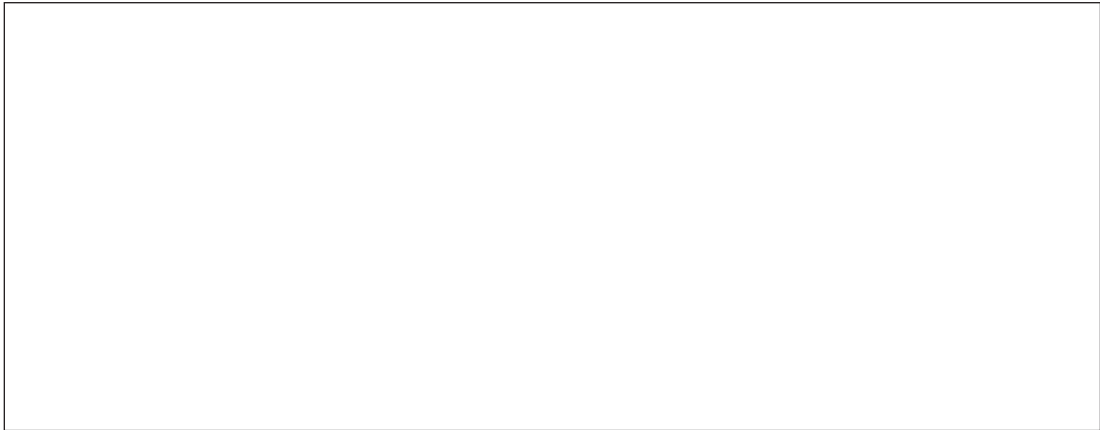

FAIRSKQ (TAIWAN) Co.,Ltd.



〈会社概要〉

会社名：友迦工業股份有限公司

設立：1978年

資本金：3.4 million USD

本社：No.186 YUNG CHI ROAD, TAIPEI 110, TAIWAN, R.O.C

URL：http://fsq.com.tw

主な取引先：旭精工株式会社ほか国内有力ベアリングメーカー2社

スウェーデン 有力ベアリングメーカー

ドイツ 有力ベアリングメーカー



在庫型番

SN505~SN532	SNZ205~SNZ232	SD534~SD560
SN605~SN632	SNZ305~SNZ332	SD634~SD656
SN205~SN232	SN3024~SN3052	SD3034~SD3068
SN305~SN332	SN3122~SN3138	SD3134~SD3160

ハウジングの呼び番号

Housing Designation

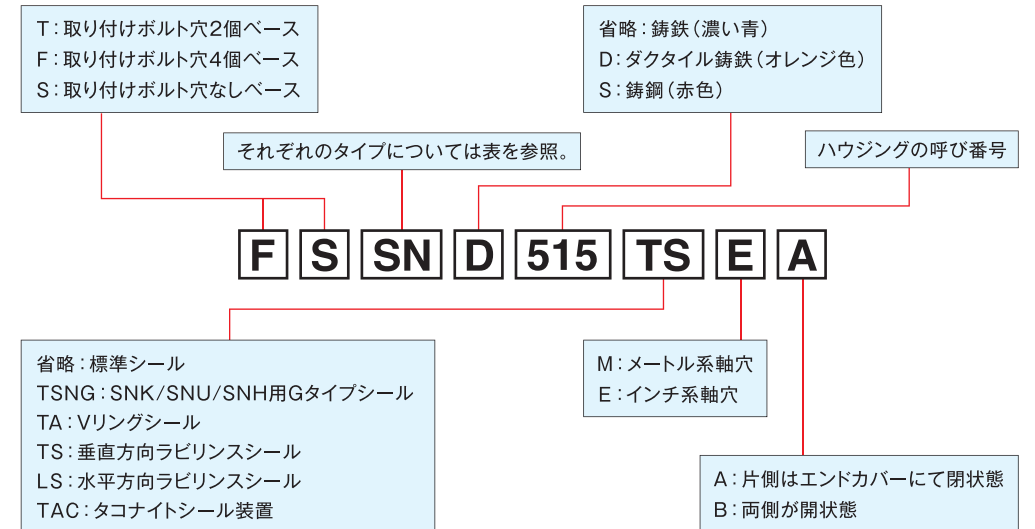

規格 / 許容回転数

Standard & Tolerances

1. 原材料

カタログに記載のスプリット軸受台ベアリングハウジングは鋳造品であり、ISO/R113-1994規格に基づいて製造されています (B.S.1642:1969規格、JIS B1551-1968規格)。以下の表は、原材料の標準化状況ならびに相対的な加工時許容回転数(ハウジングおよび付属品を含む)を表したものです。

A. ハウジング

原材料	ISOコード	米国規格コード	引張強度 kgf/mm ²	降伏強度 kgf/mm ²	伸び
鋳鉄	グレード200 (FC200)	ASTM A48 グレード 30	20	—	—
ダクタイル鋳鉄 (S.G.)	グレード450-10 (FCD450)	ASTM A536 グレード 65-45-12	45	30	10%
鋳鋼	グレード230-450 (SC450)	ASTM A27 グレード 65-35	46	23	19%

※ステンレス鋳物材も製作できます。

B. 付属品

名称	部品番号	原材料
フェルト	FS	毛80%、レーヨン20%、密度0.25g/cm ³
位置決めリング	SR	FC200
六角ボルト	M	軟鋼 AISI 1010 (SS41) / グレード8.8
ZF型シール	ZF	ニトリルゴム
TC型シール	OSM	ニトリルゴム
U-LOKシール	U-500	ニトリルゴム
TSNGシール	TSNG500	ニトリルゴム
Vリングシール	TSNA500	ニトリルゴム、軟鋼板
ラビリンスシール	TS/LER	鋳鉄 / アルミ
タコナイト運搬装置	TAC/TER/TACK	鋳鉄
エンドカバー	EPS	FC200
エンドプレート	P	軟鋼板
エンドカバー	TSA	鋳鉄
エンドプラグ	EPR	ニトリルゴム、軟鋼板
アイボルト	W/M	軟鋼 AISI 1010

※注意: このカタログに記載の事項は予告なく変更することがあります。

規格 / 許容回転数

Standard & Tolerances

2. 機械許容回転数

A. ハウジング内径

内径 mm	G7	H7	H8	J7
10 - 18	+24 +6	+18 -0	+27 -0	+10 -8
18 - 30	+28 +7	+21 -0	+33 -0	+12 -9
30 - 50	+34 +9	+25 -0	+39 -0	+14 -11
50 - 80	+40 +10	+30 -0	+46 -0	+18 -12
80 - 120	+47 +12	+35 -0	+54 -0	+22 -13
120 - 180	+54 +14	+40 -0	+63 -0	+26 -14
180 - 250	+61 +15	+46 -0	+72 -0	+30 -16
250 - 315	+69 +17	+52 -0	+81 -0	+36 -16
315 - 400	+75 +18	+57 -0	+89 -0	+39 -18
400 - 500	+83 +20	+63 -0	+97 -0	+43 -20
500 - 620	+92 +23	+70 -0	+110 -0	+46 -23

B. ハウジング内径以外

寸法 mm	H10	H11	H12	H13	h13
10 - 18	+70 -0	+110 -0	+180 -0	+270 -0	+0 -270
18 - 30	+84 -0	+130 -0	+210 -0	+330 -0	+0 -330
30 - 50	+100 -0	+160 -0	+250 -0	+390 -0	+0 -390
50 - 80	+120 -0	+190 -0	+300 -0	+460 -0	+0 -460
80 - 120	+140 -0	+220 -0	+350 -0	+540 -0	+0 -540
120 - 180	+160 -0	+250 -0	+400 -0	+630 -0	+0 -630
180 - 250	+185 -0	+290 -0	+460 -0	+720 -0	+0 -720
250 - 315	+210 -0	+320 -0	+520 -0	+810 -0	+0 -810
315 - 400	+230 -0	+360 -0	+570 -0	+890 -0	+0 -890

C. ベアリングハウジング許容回転数の選定

条件		例	ISOによる許容回転数番号
方向不定荷重	普通荷重、軽荷重、望ましい外輪のアキシャル変位	電気モーター、ポンプ、クランクシャフトメインベアリング	J7
	衝撃荷重、一時完了除荷	鉄道車両の軸箱	
外輪固定荷重	全荷重	ベアリング利用全般、鉄道車両の軸箱	H7
	普通荷重、軽荷重、単純作業時の荷重	ラインシャフトの軸材	H8
	軸を通した伝熱	ドライヤーシリンダー	G7

SNKハウジング
SNK Housings

SNA/SNU/SNH/SNN/SNV/SNLと互換します。

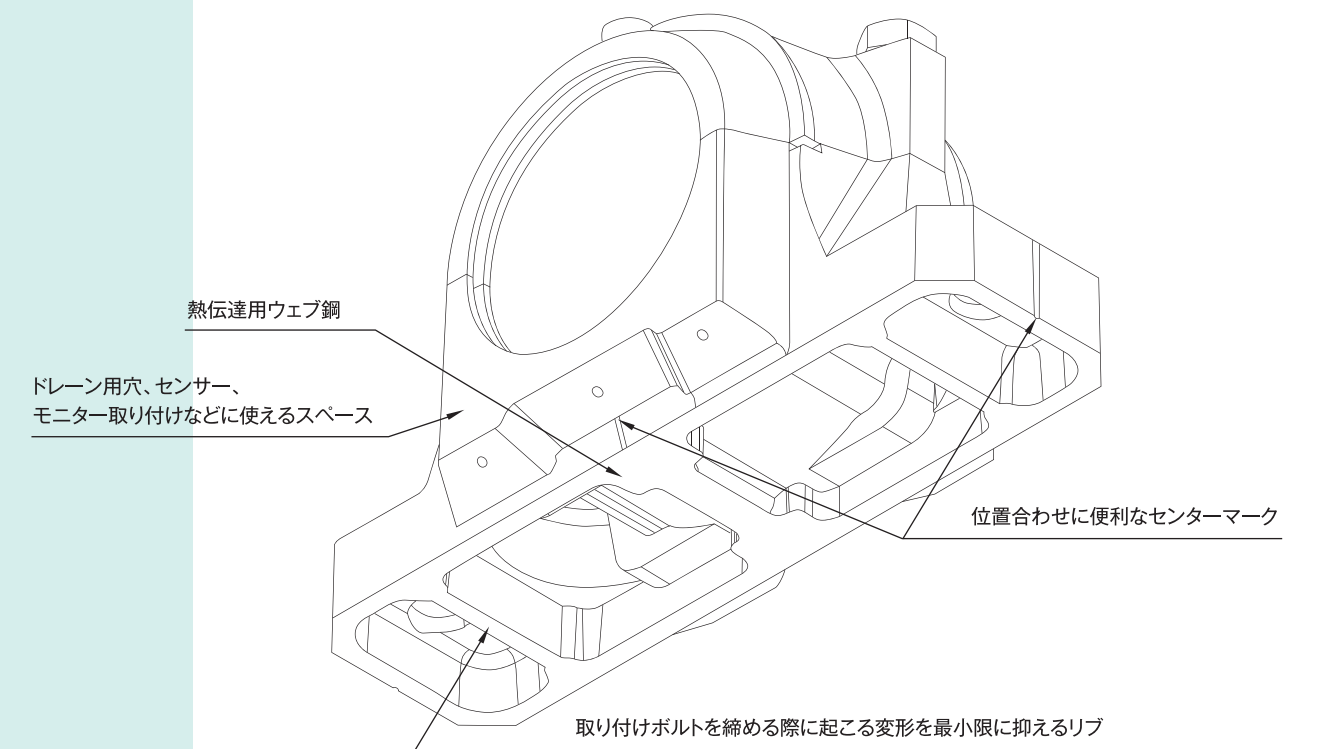
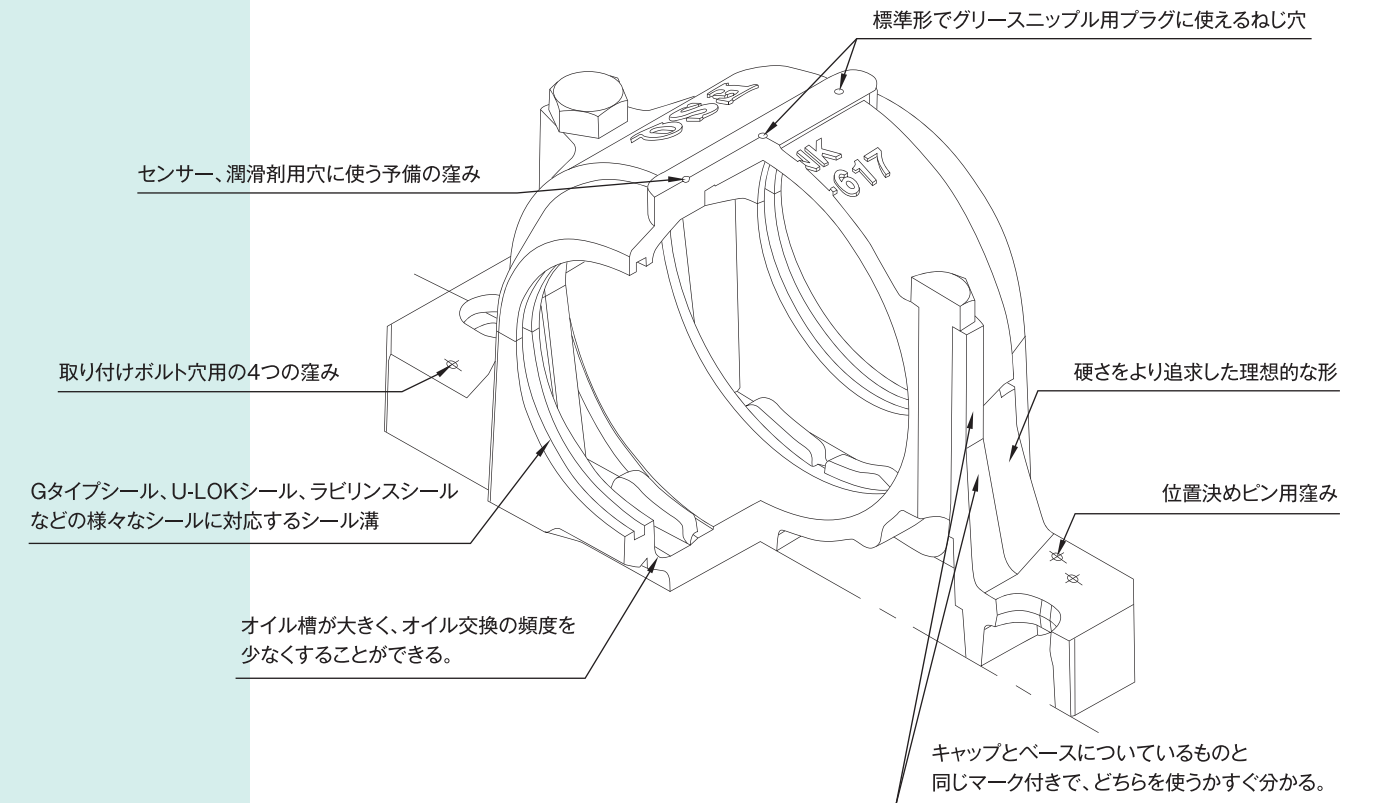

SN500型

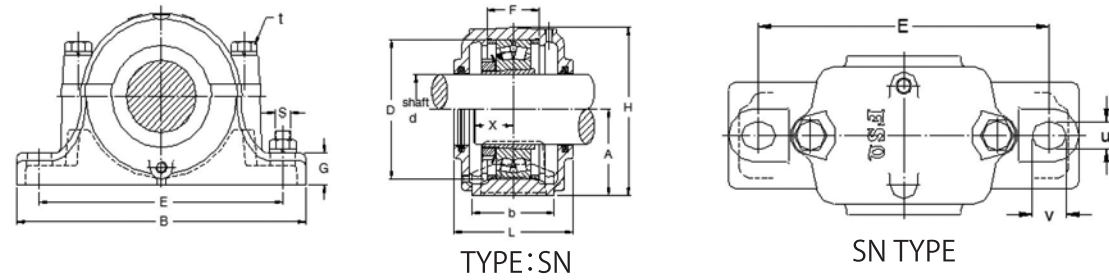

TYPE:SN

SN TYPE

型番	価格(円)	D	B	b	G	F	A	L	H	E	X	U	V	S	重量(kg)
SN505	7,610	52	165	46	22	25	40	67	75	130	22	15	20	M12	1.50
506	7,900	62	185	52	22	30	50	77	90	150	22	15	20	M12	1.74
507	8,100	72	185	52	22	33	50	82	95	150	24	15	20	M12	1.90
508	9,100	80	205	60	25	33	60	85	110	170	26	15	20	M12	2.63
SN509	9,500	85	205	60	25	31	60	85	112	170	28	15	20	M12	2.64
510	10,000	90	205	60	25	33	60	90	115	170	28	15	20	M12	2.80
511	12,500	100	255	70	28	33	70	95	130	210	30	18	23	M16	4.32
512	13,500	110	255	70	30	38	70	105	135	210	32	18	23	M16	4.99
SN513	16,200	120	275	80	30	43	80	110	150	230	36	18	23	M16	5.64
514	—	125	275	80	30	44	80	115	155	230	36	18	23	M16	7.00
515	17,800	130	280	80	30	41	80	115	155	230	38	18	23	M16	6.19
516	23,800	140	315	90	32	43	95	120	175	260	40	22	27	M20	8.17
SN517	25,700	150	320	90	32	46	95	125	185	260	42	22	27	M20	9.37
518	29,500	160	345	100	35	62.4	100	145	195	290	50	22	27	M20	11.50
519	32,300	170	345	100	35	53	112	140	210	290	—	22	27	M20	13.50
520	40,000	180	380	110	40	70.3	112	160	218	320	54	26	32	M24	16.30
SN522	47,500	200	410	120	45	80	125	175	240	350	60	26	32	M24	25.10
524	54,200	215	410	120	45	86	140	185	270	350	64	26	32	M24	27.20
526	64,600	230	445	130	50	90	150	190	290	380	64	28	36	M24	35.20
528	74,100	250	500	150	50	98	150	205	305	420	70	33	42	M30	43.70
SN530	91,200	270	530	160	60	106	160	220	325	450	76	33	42	M30	45.30
532	112,000	290	550	160	60	114	170	235	345	470	80	33	42	M30	50.75
534	見積り	310	635	170	70	120	180	240	370	525	80	34	44	M30	73.60

異口径プランマー

SN200型

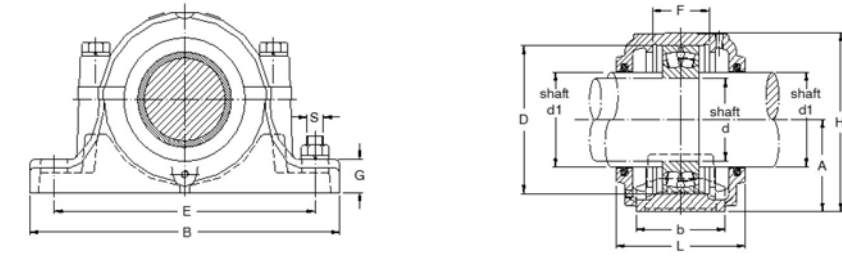

型番	価格(円)	シャフト径		D	B	b	G	F	A	L	H	E	S	ZFシール	重量(kg)	ENDカバー
		d	d1													
SN205	12,540	25	30	52	165	46	22	25	40	67	75	130	M12	ZF7	1.4	EPS07
206	13,020	30	35	62	185	52	22	30	50	77	90	150	M12	ZF8	2.2	EPS08
207	14,890	35	45	72	185	52	22	33	50	82	95	150	M12	ZF10	2.5	EPS10
208	15,200	40	50	80	205	60	25	33	60	85	110	170	M12	ZF11	3.2	EPS11
SN209	16,200	45	55	85	205	60	25	31	60	85	112	170	M12	ZF12	3.0	EPS12
210	16,440	50	60	90	205	60	25	33	60	90	115	170	M12	ZF13	3.3	EPS13
211	20,400	55	65	100	255	70	28	33	70	95	130	210	M16	ZF15	4.8	EPS15
212	21,840	60	70	110	255	70	30	38	70	105	135	210	M16	ZF16	5.3	EPS16
SN213	22,560	65	75	120	275	80	30	43	80	110	150	230	M16	ZF17	6.5	EPS17
214	24,000	70	80	125	275	80	30	44	80	115	155	230	M16	ZF18	7.0	EPS18
215	24,720	75	85	130	280	80	30	41	80	115	155	230	M16	ZF19	7.0	EPS19
216	33,120	80	90	140	315	90	32	43	95	120	175	260	M20	ZF20	9.5	EPS20
SN217	34,200	85	95	150	320	90	32	46	95	125	185	260	M20	ZF21	10.5	EPS21
218	44,400	90	100	160	345	100	35	62.4	100	145	195	290	M20	ZF22	13.0	EPS22
219	54,000	95	110	170	345	100	35	53	112	140	210	290	M20	ZF24	15.5	EPS24
220	56,400	100	115	180	380	110	40	70.3	112	160	218	320	M24	ZF26	20.5	EPS26
SN222	66,000	110	125	200	410	120	45	80	125	175	240	350	M24	ZF28	26.2	ESP28
224	75,600	120	135	215	410	120	45	86	140	185	270	350	M24	ZF30	34.6	EPS30
226	90,000	130	145	230	445	130	50	90	150	190	290	380	M24	ZF33	41.8	EPS33
228	103,200	140	155	250	500	150	50	98	150	205	305	420	M30	ZF35	53.5	EPS35
SN230	156,000	150	165	270	530	160	60	106	160	220	325	450	M30	ZF37	58.2	EPS37
232	183,000	160	175	290	550	160	60	114	170	235	345	470	M30	ZF39	72.5	EPS39

SN600型

型番	価格(円)	D	B	b	G	F	A	L	H	E	X	U	V	S	重量(kg)
SN605	8,140	60	185	52	22	34	50	80	90	150	27	15	20	M12	2.11
606	8,450	72	185	52	22	37	50	82	95	150	27	15	20	M12	2.09
607	9,700	80	205	60	25	41	60	90	110	170	32	15	20	M12	3.40
608	10,500	90	205	60	25	43	60	95	115	170	34	15	20	M12	3.60
SN609	12,400	100	255	70	28	46	70	105	130	210	36	18	23	M16	5.30
610	13,500	110	255	70	30	50	70	115	135	210	39	18	23	M16	5.50
611	17,400	120	275	80	30	53	80	120	150	230	40	18	23	M16	6.90
612	17,900	130	280	80	30	56	80	125	155	230	44	18	23	M12	8.80
SN613	22,600	140	315	90	32	58	95	130	175	260	46	22	27	M20	9.80
614	—	150	320	90	32	61	95	130	185	260	46	22	27	M20	11.50
615	28,500	160	345	100	35	65	100	140	195	290	51	22	27	M20	13.00
616	33,300	170	345	100	35	68	112	145	212	290	52	22	27	M20	15.50
SN617	40,000	180	380	110	40	70	112	155	223	320	56	26	32	M24	16.30
618	43,500	190	380	110	40	74	112	160	230	320	58	26	32	M24	20.00
619	53,200	200	410	120	45	77	125	170	250	350	60	26	32	M24	28.00
620	58,900	215	410	120	45	83	140	175	270	350	64	26	32	M24	30.50
SN622	74,400	240	450	130	50	90	150	190	300	390	69	28	36	M24	42.00
624	100,000	260	530	160	60	96	160	205	320	450	73	33	42	M30	59.00
626	116,000	280	550	160	60	103	170	215	340	470	77	33	42	M30	61.50
628	142,500	300	610	170	65	112	180	235	365	520	83	35	45	M30	88.00
SN630	166,300	320	650	180	65	118	190	245	385	560	88	35	45	M30	89.00
632	190,000	340	680	190	70	124	200	255	405	580	93	42	50	M36	127.00

SN300型

型番	価格(円)	シャフト径		D	B	b	G	F	A	L	H	E	S	ZFシール	重量(kg)	ENDカバー
		d	d1													
SN305	15,200	25	30	60	185	52	22	34	50	80	90	150	M12	ZF7	1.9	EPS07
306	15,810	30	35	72	185	52	22	37	50	82	95	150	M12	ZF8	2.2	EPS08
307	18,100	35	45	80	205	60	25	41	60	90	110	170	M12	ZF10	3.5	EPS10
308	18,480	40	50	90	205	60	25	43	60	95	115	170	M12	ZF11	3.4	EPS11
SN309	20,400	45	55	100	255	70	28	46	70	105	130	210	M16	ZF12	5.2	EPS12
310	22,800	50	60	110	255	70	30	50	70	115	135	210	M16	ZF13	5.3	EPS13
311	23,760	55	65	120	275	80	30	53	80	120	150	230	M16	ZF15	6.5	EPS15
312	25,200	60	70	130	280	80	30	56	80	125	155	230	M16	ZF16	8.0	EPS16
SN313	32,400	65	75	140	315	90	32	58	95	130	175	260	M20	ZF17	10.0	EPS17
314	38,400	70	80	150	320	90	32	61	95	130	185	260	M20	ZF18	11.0	EPS18
315	40,620	75	85	160	345	100	35	65	100	140	195	290	M20	ZF19	12.8	EPS19
316	46,800	80	90	170	345	100	35	68	112	145	212	290	M20	ZF20	15.0	EPS20
SN317	56,400	85	95	180	380	110	40	70	112	155	223	320	M24	ZF21	15.8	EPS21
318	61,200	90	100	190	380	110	40	74	112	160	230	320	M24	ZF22	19.4	EPS22
319	72,360	95	110	200	410	120	45	77	125	170	250	350</				

異口径プランマー

SNZ200型

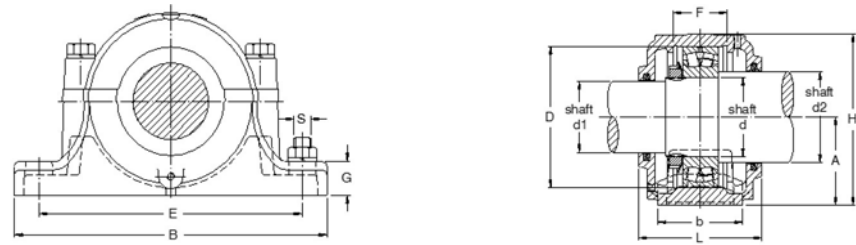

型番	価格(円)	シャフト径			D	B	b	G	F	A	L	H	E	S	ZFシール		ENDカバー
		d	d1	d2											d1	d2	
SNZ205	12,540	25	20	30	52	165	46	22	25	40	67	75	130	M12	ZF5	ZF7	EPS05
206	13,020	30	25	35	62	185	52	22	30	50	77	90	150	M12	ZF6	ZF8	EPS06
207	14,890	35	30	45	72	185	52	22	33	50	82	95	150	M12	ZF7	ZF10	EPS07
208	15,200	40	35	50	80	205	60	25	33	60	85	110	170	M12	ZF8	ZF11	EPS08
SNZ209	16,200	45	40	55	85	205	60	25	31	60	85	112	170	M12	ZF9	ZF12	EPS09
210	16,440	50	45	60	90	205	60	25	33	60	90	115	170	M12	ZF10	ZF13	EPS10
211	20,400	55	50	65	100	255	70	28	33	70	95	130	210	M16	ZF11	ZF15	EPS11
212	21,840	60	55	70	110	255	70	30	38	70	105	135	210	M16	ZF12	ZF16	EPS12
SNZ213	22,560	65	60	75	120	275	80	30	43	80	110	150	230	M16	ZF13	ZF17	EPS13
214	24,000	70	60	80	125	275	80	30	44	80	115	155	230	M16	ZF13	ZF18	EPS13
215	24,720	75	65	85	130	280	80	30	41	80	115	155	230	M16	ZF15	ZF19	EPS15
216	33,120	80	70	90	140	315	90	32	43	95	120	175	260	M20	ZF16	ZF20	EPS16
SNZ217	34,200	85	75	95	150	320	90	32	46	95	125	185	260	M20	ZF17	ZF21	EPS17
218	44,400	90	80	100	160	345	100	35	62.4	100	145	195	290	M20	ZF18	ZF22	EPS18
219	54,000	95	85	110	170	345	100	35	53	112	140	210	290	M20	ZF19	ZF24	EPS19
220	56,400	100	90	115	180	380	110	40	70.3	112	160	218	320	M24	ZF20	ZF26	EPS20
SNZ222	66,000	110	100	125	200	410	120	45	80	125	175	240	350	M24	ZF22	ZF28	ESP22
224	75,600	120	110	135	215	410	120	45	86	140	185	270	350	M24	ZF24	ZF30	EPS24
226	90,000	130	115	145	230	445	130	50	90	150	190	290	380	M24	ZF26	ZF33	EPS26
228	103,200	140	125	155	250	500	150	50	98	150	205	305	420	M30	ZF28	ZF35	EPS28
SNZ230	156,000	150	135	165	270	530	160	60	106	160	220	325	450	M30	ZF30	ZF37	EPS30
232	183,000	160	140	175	290	550	160	60	114	170	235	345	470	M30	ZF32	ZF39	EPS32

SNZ300型

型番	価格(円)	シャフト径			D	B	b	G	F	A	L	H	E	S	ZFシール		ENDカバー
		d	d1	d2											d1	d2	
SNZ305	15,200	25	20	30	60	185	52	22	34	50	80	90	150	M12	ZF5	ZF7	EPS05
306	15,810	30	25	35	72	185	52	22	37	50	82	95	150	M12	ZF6	ZF8	EPS06
307	18,100	35	30	45	80	205	60	25	41	60	90	110	170	M12	ZF7	ZF10	EPS07
308	18,480	40	35	50	90	205	60	25	43	60	95	115	170	M12	ZF8	ZF11	EPS08
SNZ309	20,400	45	40	55	100	255	70	28	46	70	105	130	210	M16	ZF9	ZF12	EPS09
310	22,800	50	45	60	110	255	70	30	50	70	115	135	210	M16	ZF10	ZF13	EPS10
311	23,760	55	50	65	120	275	80	30	53	80	120	150	230	M16	ZF11	ZF15	EPS11
312	25,200	60	55	70	130	280	80	30	56	80	125	155	230	M16	ZF12	ZF16	EPS12
SNZ313	32,400	65	60	75	140	315	90	32	58	95	130	175	260	M20	ZF13	ZF17	EPS13
314	38,400	70	60	80	150	320	90	32	61	95	130	185	260	M20	ZF13	ZF18	EPS13
315	40,620	75	65	85	160	345	100	35	65	100	140	195	290	M20	ZF15	ZF19	EPS15
316	46,800	80	70	90	170	345	100	35	68	112	145	212	290	M20	ZF16	ZF20	EPS16
SNZ317	56,400	85	75	95	180	380	110	40	70	112	155	223	320	M24	ZF17	ZF21	EPS17
318	61,200	90	80	100	190	380	110	40	74	112	160	230	320	M24	ZF18	ZF22	EPS18
319	72,360	95	85	110	200	410	120	45	77	125	170	250	350	M24	ZF19	ZF24	EPS19
320	82,800	100	90	115	215	410	120	45	83	140	175	270	350	M24	ZF20	ZF26	EPS20
SNZ322	100,800	110	100	125	240	450	130	50	90	150	190	300	390	M24	ZF22	ZF28	ESP22
324	132,000	120	110	135	260	530	160	60	96	160	205	320	450	M30	ZF24	ZF30	EPS24
326	136,400	130	115	150	280	550	160	60	103	170	215	340	470	M30	ZF26	ZF34	EPS26
328	161,600	140	125	160	300	610	170	65	112	180	235	365	520	M30	ZF28	ZF36	EPS28
SNZ330	193,400	150	135	170	320	650	180	65	118	190	245	385	560	M30	ZF30	ZF38	EPS30
332	241,400	160	140	180	340	680	190	70	124	200	255	405	580	M36	ZF32	ZF40	EPS32

SN3000型

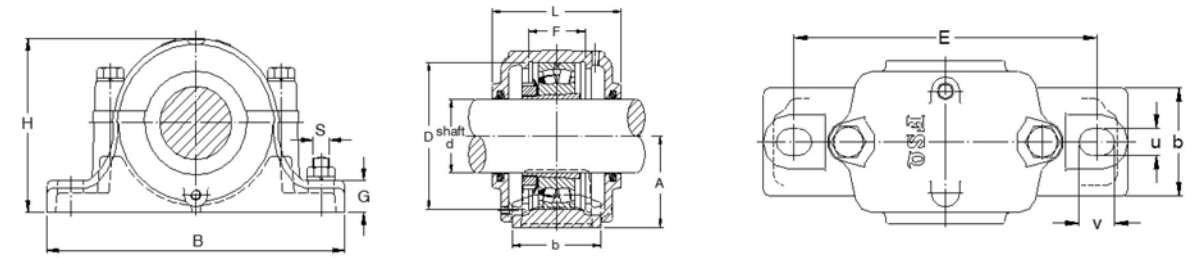

型番	価格(円)	d	D	B	b	G	F	A	L	H	E	U	V	t
SN3024	44,700	110	180	380	110	40	56	112	150	217	320	26	35	M20
3026	52,400	115	200	410	120	45	62	125	160	240	350	26	35	M20
3028	60,200	125	210	410	120	45	63	140	170	260	350	26	35	M20
3030	75,700	135	225	445	130	50	66	150	175	283	380	28	38	M24
SN3032	84,400	140	240	460	130	50	70	150	190	290	390	28	38	M24
3034	104,800	150	260	530	160	60	77	160	200	310	450	33	42	M24
3036	118,400	160	280	550	160	60	84	170	210	330	470	33	42	M24
3038	126,100	170	290	550	160	60	85	170	210	335	470	33	42	M24
SN3040	191,000	180	310	610	170	60	92	180	235	355	515	33	42	M24
3044	250,000	200	340	690	190	70	100	200	255	405	580	40	52	M30
3048	290,000	220	360	720	190	75	102	210	265	420	680	40	52	M30
3052	355,000	240	400	820	200	80	114	240	285	472	780	48	70	M30

SN3100型

型番	価格(円)	d	D	B	b	G	F	A	L	H	E	U	V	t
SN3122	46,600	100	180	380	110	40	66	112	155	217	320	26	35	M20
3124	54,400	110	200	410	120	45	72	125	165	240	350	26	35	M20
3126	61,200	115	210	410	120	45	74	140	170	260	350	26	35	M20
3128	79,600	125	225	445	130	50	78	150	180	283	380	28	38	M24
SN3130	90,000	135	250	500	150	50	90	150	200	295	420	33	42	M24
3132	110,600	140	270	530	160	60	96	160	215	315	450	33	42	M24
3134	126,200	150	280	550	160	60	98	170	220	330	470	33	42	M24
3136	174,600	160	300	610	170	70	106	180	230	355	520	33	42	M30
SN3138	213,400	170	320	650	180	70	114	190	240	375	560	33	42	M30

SD500型

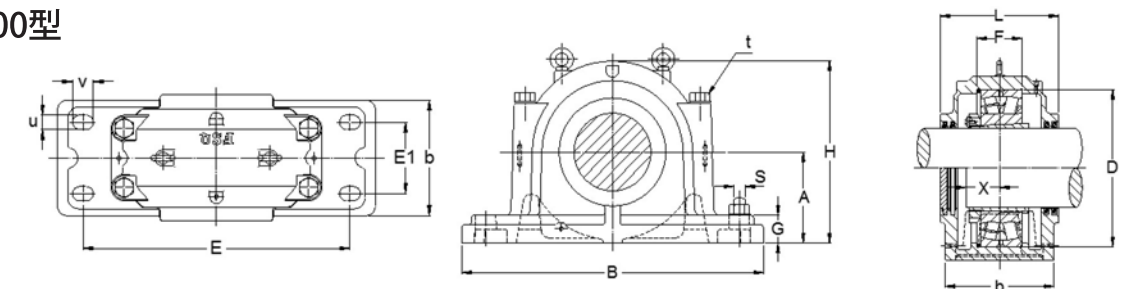

固定側にガイドリングをご使用下さい。

型番	価格(円)	d	D	A	B	E	b	G	F	H	L	E1	U	V	ガイドリング	数
SD534	174,600	150	310	180	620	510	230	60	96	360	270	140	35	52	SR310×10	1
536	186,300	160	320	190	650	540	240	60	96	380	280	150	35	52	SR320×1	

SD600型

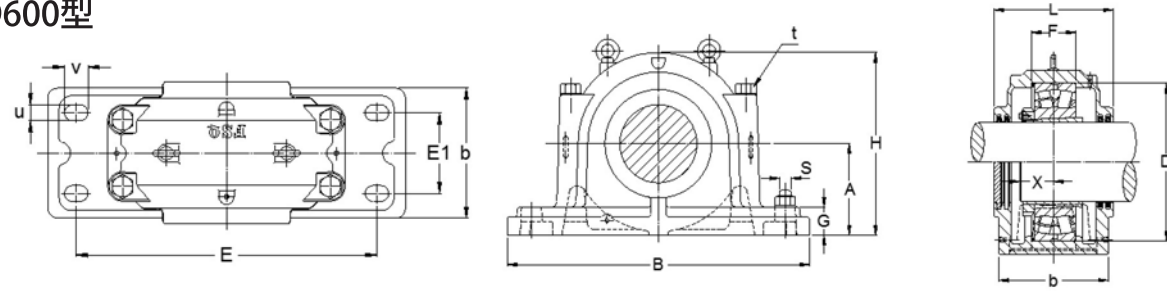

固定側にガイドリングをご使用下さい。

型番	価格(円)	d	D	A	B	E	b	G	F	H	L	E1	U	V	ガイドリング	数
SD634	310,400	150	360	210	740	610	270	65	130	420	300	170	35	55	SR360×10	1
636	340,000	160	380	225	780	640	290	70	136	450	320	180	40	60	SR380×10	1
638	417,000	170	400	240	820	680	300	70	142	475	330	190	40	60	SR400×10	1
640	524,000	180	420	250	860	710	320	85	148	500	350	200	42	62	SR420×10	1
SD644	582,000	200	460	280	920	770	330	85	155	550	360	210	42	62	SR460×10	1
648	844,000	220	500	300	990	830	370	100	165	590	390	230	50	70	SR500×10	1
652	1,070,000	240	540	325	1060	890	390	100	175	640	410	250	50	70	SR540×10	1
656	1,260,000	260	580	355	1110	930	420	110	185	690	440	270	57	77	SR580×10	1

SD3100型

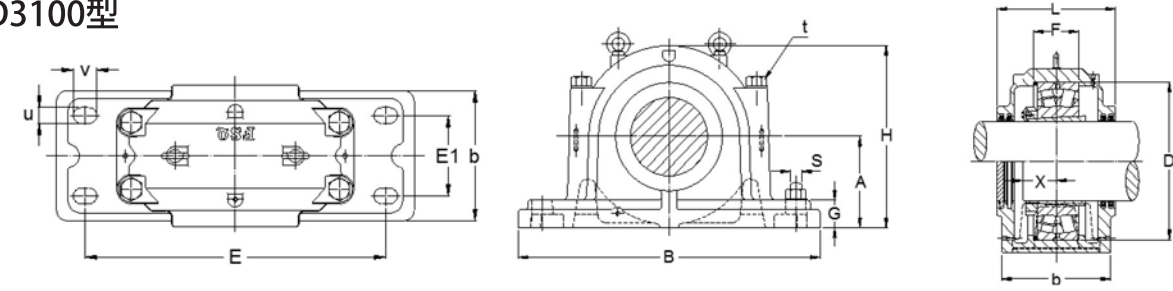

固定側にガイドリングをご使用下さい。

型番	価格(円)	d	D	A	B	E	b	G	F	H	L	E1	U	V	ガイドリング	数
SD3134	200,000	150	280	170	560	470	220	50	98	340	250	120	35	42	SR280×10	1
3136	220,000	160	300	180	630	520	250	55	106	365	270	140	35	52	SR300×10	1
3138	240,000	170	320	190	680	560	270	55	114	385	310	140	35	55	SR320×10	1
3140	260,000	180	340	200	700	570	260	65	122	400	290	160	35	55	SR340×10	1
SD3144	320,000	200	370	225	780	640	290	70	130	450	320	180	40	60	SR370×10	1
3148	370,000	220	400	240	820	680	300	70	138	475	330	190	42	62	SR400×10	1
3152	540,000	240	440	260	880	740	310	85	154	515	340	200	42	62	SR440×10	1
3156	640,000	260	460	280	920	770	330	85	156	550	360	210	42	62	SR460×10	1
SD3160	710,000	280	500	300	990	830	370	100	170	590	390	230	50	70	SR500×10	1
3164	880,000	300	540	325	1060	890	390	100	186	640	410	250	50	70	SR540×10	1
3168	1,090,000	320	580	355	1110	930	420	110	200	690	440	270	57	77	SR580×10	1
3172	見積り	340	600	365	1140	960	460	120	202	710	470	310	57	77	SR600×10	1
SD3176	見積り	360	620	375	1160	980	490	120	204	735	500	320	57	77	SR620×10	1
3180	見積り	380	650	390	1220	1040	510	125	210	765	520	340	57	77	SR650×10	1

SD3000型

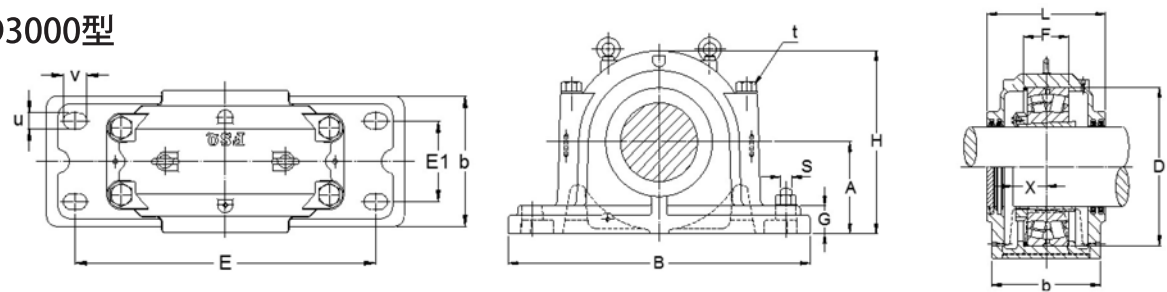

固定側にガイドリングをご使用下さい。

型番	価格(円)	d	D	A	B	E	b	G	F	H	L	E1	U	V	ガイドリング	数
SD3034	150,000	150	260	160	540	450	200	50	77	320	230	110	35	52	SR260×10	1
3036	165,000	160	280	170	560	470	220	50	84	340	250	120	35	52	SR280×10	1
3038	180,000	170	290	170	560	470	220	50	85	345	250	120	35	52	SR290×10	1
3040	185,000	180	310	180	620	510	230	60	92	360	270	140	35	55	SR310×10	1
SD3044	260,000	200	340	200	700	570	260	65	100	400	290	160	35	55	SR340×10	1
3048	301,000	220	360	210	740	610	270	65	102	420	300	170	35	55	SR360×10	1
3052	365,000	240	400	240	820	680	300	70	114	475	330	190	42	62	SR400×10	1
3056	456,000	260	420	250	860	710	320	85	116	500	350	200	42	62	SR420×10	1
SD3060	553,000	280	460	280	920	770	330	85	128	550	360	210	42	62	SR460×10	1
3064	650,000	300	480	280	940	790	340	85	131	560	370	210	42	62	SR480×10	1
3068	852,000	320	520	310	1020	860	370	100	143	615	400	230	50	70	SR520×10	1
3072	956,000	340	540	325	1060	890	390	100	144	640	410	250	50	70	SR540×10	1
3076	997,000	360	560	340	1080	900	390	100	145	665	410	260	50	70	SR560×10	1

エンドカバー

EPS型

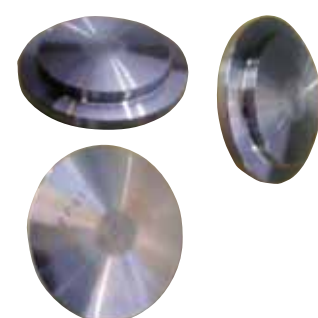

型番	価格(円)	型番	価格(円)	型番	価格(円)
EPS05	2,200	EPS16	3,800	EPS34	18,000
06	2,300	17	3,900	36	20,000
07	2,400	18	4,400	38	26,000
08	2,500	19	6,300	40	27,000
EPS09	2,600	EPS20	6,860	EPS44	35,000
10	2,700	22	7,600	48	45,000
11	3,000	24	8,400	52	54,000
12	3,300	26	8,400	56	65,000
EPS13	3,600	EPS28	11,100	EPS60	114,000
14	3,700	30	12,300	64	171,000
15	3,800	32	13,000	68	200,000



We Bear The Rolling World

CSD32-500



Weight 1,750kg

SD556



SOFN226



SSDS231-710

Weight 2,950kg
length 1,900mm



SD3152

ガイドリング価格表と組み合わせ表

型番構成 SR 52 × 5
外径 幅

型番	価格(円)	外径	幅	適用プランマ	ベアリング	アダプタ	数
SR52×5	1,000	52	5	SN505 SN205/SNZ205	1205K 1205	H205 AN05/AW05	2 2
SR52×7	1,000		7	SN505 SN205/SNZ205	2205K/22205K 2205/22205	H305 AN05/AW05	1 1
SR62×7	1,100	62	7	SN506 SN206/SNZ206	1206K 1206	H206 AN06/AW06	2 2
SR62×8.5	1,100		8.5	SN605 SN305/SNZ305	1305K 1305	H305 AN05/AW05	2 2
SR62×10	1,100	62	10	SN506 SN605 SN206/SNZ206 SN305/SNZ305	2206K/22205K 2305K 2206/22206 2305	H306 H2305 AN06/AW06 AN05/AW05	1 1 1 1
SR72×8	1,160		8	SN507 SN207/SNZ207	1207K 1207	H207 AN07/AW07	2 2
SR72×9	1,200	72	9	SN606 SN306/SNZ306	1306K 1306	H306 AN06/AW06	2 2
SR72×10	1,200		10	SN507 SN606 SN207/SNZ207 SN306/SNZ306	2207K/22207K 2306K 2207/22207 2306	H307 H2306 AN07/AW07 AN06/AW06	1 1 1 1
SR80×7.5	1,220	80	7.5	SN508 SN208/SNZ208	1208K 1208	H208 AN08/AW08	2 2
SR80×10	1,300		10	SN508 SN607 SN208/SNZ208 SN307/SNZ307 SN307/SNZ307	2208K/22208K 1307K 2307K 2208/22208 1307 2307	H308 H307 H2307 AN08/AW08 AN07/AW07 AN07/AW07	1 2 1 1 2 1
SR85×6	1,300	85	6	SN509 SN209/SNZ209	1209K 1209	H209 AN09/AW09	2 2
SR85×8	1,350		8	SN509 SN209/SNZ209	2209K/22209K 2209/22209	H309 AN09/AW09	1 1
SR90×6.5	1,460	90	6.5	SN510 SN210/SNZ210	1210K 1210	H210 AN10/AW10	2 2
SR90×10	1,550		10	SN510 SN608 SN608 SN210/SNZ210 SN308/SNZ308 SN308/SNZ308	2210K/22210K 1308K/21308K 2308K/22308K 2210/22210 1308/21308 2308/22308	H310 H308 H2308 AN10/AW10 AN08/AW08 AN08/AW08	1 2 1 1 2 1
SR100×6	1,700	100	6	SN511 SN211/SNZ211	1211K 1211	H211 AN11/AW11	2 2
SR100×8	1,750		8	SN511 SN211/SNZ211	2211K/22211K 2211/22211	H311 AN11/AW11	1 1
SR100×10	1,800	100	10	SN609 SN309/SNZ309	2309K/22309K 2309/22309	H2309 AN09/AW09	1 1
SR100×10.5	1,800		10.5	SN609 SN309/SNZ309	1309K/21309K 1309/21309	H309 AN09/AW09	2 2
SR110×8	1,800	110	8	SN512 SN212/SNZ212	1212K 1212	H212 AN12/AW12	2 2
SR110×10	1,850		10	SN512 SN610 SN212/SNZ212 SN310/SNZ310	2212K/22212K 2310K/22310K 2212/22212 2310/22310	H312 H2310 AN12/AW12 AN10/AW10	1 1 1 1
SR110×11.5	1,900	110	11.5	SN610 SN310/SNZ310	1310K/21310K 1310/21310	H310 AN10/AW10	2 2
SR120×10	2,100		10	SN513 SN611 SN213/SNZ213 SN311/SNZ311	1213K 2311K/22311K 1213 2311/22311	H213 H2311 AN13/AW13 AN11/AW11	2 1 2 1
SR120×12	2,160	120	12	SN513 SN611 SN213/SNZ213 SN311/SNZ311	2213K/22213K 1311K/21311K 2213/22213 1311/21311	H313 H311 AN13/AW13 AN11/AW11	1 2 1 2
SR125×10	2,400		125	10	SN214/SNZ214	1214	AN14/AW14

ガイドリング価格表と組み合わせ表

型番構成 SR 52 × 5
外径 幅

型番	価格(円)	外径	幅	適用プランマ	ベアリング	アダプタ	数
SR125×13	2,500	125	13	SN214/SNZ214	2214/22214	AN14/AW14	1
SR130×8	2,350	130	8	SN515 SN215/SNZ215	1215K 1215	H215 AN15/AW15	2 2
SR130×10	2,400		10	SN515 SN612 SN215/SNZ215 SN312/SNZ312	2215K/22215K 2312K/22312K 2215/22215 2312/22312	H315 H2312 AN15/AW15 AN12/AW12	1 1 1 1
SR130×12.5	2,500	130	12.5	SN612 SN312/SNZ312	1312K/21312K 1312/21312	H312 AN12/AW12	2 2
SR140×8.5	2,600		8.5	SN516 SN216/SNZ216	1216K 1216	H216 AN16/AW16	2 2
SR140×10	2,600	140	10	SN516 SN613 SN216/SNZ216 SN313/SNZ313	2216K/22216K 2313K/22313K 2216/22216 2313/22313	H316 H2313 AN16/AW16 AN13/AW13	1 1 1 1
SR140×12.5	2,700		12.5	SN613 SN313/SNZ313	1313K/21313K 1313/21313	H313 AN13/AW13	2 2
SR150×9	2,900	150	9	SN517 SN217/SNZ217	1217K 1217	H217 AN17/AW17	2 2
SR150×10	2,900		10	SN517 SN217/SNZ217 SN314/SNZ314	2217K/22217K 2217/22217 22314	H317 AN17/AW17 AN14/AW14	1 1 1
SR150×13	3,500	150	13	SN314/SNZ314	1314/21314	AN14/AW14	2
SR160×10	3,500		10	SN518 SN615 SN218/SNZ218 SN315/SNZ315	23218K 2315K/22315K 23218 2315/22315	H2318 H2315 AN18/AW18 AN15/AW15	1 1 1 1
SR160×11.2	3,500	160	11.2	SN518 SN218/SNZ218	2218K/22218K 2218/22218	H318 AN18/AW18	2 2
SR160×14	3,800		14	SN615 SN315/SNZ315	1315K/21315K 1315/21315	H315 AN15/AW15	2 2
SR160×16.2	4,300	160	16.2	SN518 SN218/SNZ218	1218K 1218	H218 AN18/AW18	2 2
SR170×10	3,700		10	SN519 SN616 SN219/SNZ219 SN316/SNZ316	22219K 2316K/22316K 2219/22219 2316/22316	H319 H2316 AN19/AW19 AN16/AW16	1 1 1 1
SR170×10.5	3,750	170	10.5	SN519 SN219/SNZ219	1219K 1219	H219 AN19/AW19	2 2
SR170×14.5	4,000		14.5	SN616 SN316/SNZ316	1316K/21316K 1316/21316	H316 AN16/AW16	2 2
SR180×10	4,000	180	10	SN520 SN617 SN220/SNZ220 SN317/SNZ317 SN3024 SN3122	23220K 2317K/22317K 23220 2317/22317 23024K 23122K	H2320 H2317 AN20/AW20 AN17/AW17 H3024 H3122	1 1 1 1 1 1
SR180×12.1	4,400		12.1	SN520 SN220/SNZ220	2220K/22220K 2220/22220	H320 AN20/AW20	2 2
SR180×14.5	4,500	180	14.5	SN617 SN317/SNZ317	1317K/21317K 1317/21317	H317 AN17/AW17	2 2
SR190×10	4,400		10	SN618 SN318/SNZ318	2318K/22318K 2318/22318	H2318 AN18/AW18	1 1
SR190×15.5	5,900	190	15.5	SN618 SN318/SNZ318	1318K 1318/21318	H318 AN18/AW18	2 2
SR200×10	4,700		10	SN522 SN619 SN222/SNZ222 SN319/SNZ319 SN3026 SN3124	23222K 2319K/22319K 23222 2319/22319 23026K 23124K	H2322 H2319 AN22/AW22 AN19/AW19 H3026 H3124	1 1 1 1 1 1
SR200×13.5	5,700	200	13.5	SN522 SN222/SNZ222	2222K/22222K 2222/22222	H322 AN22/AW22	2 2
SR200×16	7,100		16	SN619 SN319/SNZ319	1319K 1319/21319	H319 AN19/AW19	2 2

ガイドリング価格表と組み合わせ表

型番構成 SR 52 × 5
外径 幅

型番	価格(円)	外径	幅	適用プランマ	ベアリング	アダプタ	数
SR210×10	5,300	210	10	SN3028 SN3126	23028K 23126K	H3028 H3126	1 1
SR215×10	5,400	215	10	SN524 SN620 SN224/SNZ224 SN320/SNZ320	23224K 2320K/22320K 23224 2320/22320	H2324 H2320 AN24/AW24 AN20/AW20	1 1 1 1
SR215×14	6,200		14	SN524 SN224/SNZ224	22224K 22224	H3124 AN24/AW24	2 2
SR215×18	9,600		18	SN620 SN320/SNZ320	1320K 1320/21320	H320 AN20/AW20	2 2
SR225×10	6,800	225	10	SN3030 SN3128	23030K 23128K	H3030 H3128	1 1
SR230×10	6,800	230	10	SN526 SN226/SNZ226	23226K 23226	H2326 AN26/AW26	1 1
SR230×13	8,000		13	SN526 SN226/SNZ226	22226K 22226	H3126 AN26/AW26	2 2
SR240×10	8,000	240	10	SN622 SN322/SNZ322 SN3032	2322K/22322K 22322 23032K	H2322 AN22/AW22 H3032	1 1 1
SR240×20	11,200		20	SN622 SN322/SNZ322	1322K 21322	H322 AN22/AW22	2 2
SR250×10	9,100	250	10	SN528 SN228/SNZ228 SN3130	23228K 23228 23130K	H2328 AN28/AW28 H3130	1 1 1
SR250×15	10,500		15	SN528 SN228/SNZ228	22228K 22228	H3128 AN28/AW28	2 2
SR260×10	9,700	260	10	SN624 SN324/SNZ324 SN3034 SD3034	22324K 22324 23034K 23034K	H2324 AN24/AW24 H3034 H3034	1 1 1 1
SR270×10	10,800	270	10	SN530 SN230/SNZ230 SN3132	23230K 23230 23132K	H2330 AN30/AW30 H3132	1 1 1
SR270×16.5	12,000		16.5	SN530 SN230/SNZ230	22230K 22230	H3130 AN30/AW30	2 2
SR280×10	11,400	280	10	SN626 SN326/SNZ326 SN3036 SN3134 SD3036	22326K 22326 23036K 23134K 23036K	H2326 AN26/AW26 H3036 H3134 H3036	1 1 1 1 1
SR290×10	16,000	290	10	SN532 SN232/SNZ232 SN3038 SD3038	23232K 23232 23038K 23038K	H2332 AN32/AW32 H3038 H3038	1 1 1 1
SR290×17	18,000		17	SN532 SN232/SNZ232	22232K 22232	H3132 AN32/AW32	2 2
SR300×10	17,000	300	10	SN628 SN328/SNZ328 SN3136	22328K 22328 23136K	H2328 AN28/AW28 H3136	1 1 1
SR310×10	17,500	310	10	SN534 SN3040 SD534 SD3040	23234K 23040K 22234K 23040K	H2334 H3040 H3134 H3040	1 1 1 1
SR320×10	18,000	320	10	SN630 SN330/SNZ330 SN3138 SD536	22330K 22330 23138K 22236K	H2330 AN30/AW30 H3138 H3136	1 1 1 1
SR340×10	18,500	340	10	SN632 SN332/SNZ332 SN3044 SD538 SD3044	22332K 22332 23044K 22238K 23044K	H2332 AN32/AW32 H3044 H3138 H3044	1 1 1 1 1
SR360×10	22,000	360	10	SD540 SD634 SD3048	22240K 22334K 23048K	H3140 H2334 H3048	1 1 1

ガイドリング価格表と組み合わせ表

型番構成 SR 52 × 5
外径 幅

型番	価格(円)	外径	幅	適用プランマ	ベアリング	アダプタ	数
SR380×10	29,000	380	10	SD636	22336K	H2336	1
SR400×10	35,000	400	10	SD544 SD638 SD3052	22244K 22338K 23052K	H3144 H2338 H3052	1 1 1
SR420×10	36,000	420	10	SD640 SD3056	22340K 23056K	H2340 H3056	1 1
SR440×10	37,000	440	10	SD548	22248K	H3148	1
SR460×10	39,000	460	10	SD644 SD3060	22344K 23060K	H2344 H3060	1 1
SR480×10	40,000	480	10	SD552 SD3064	22252K 23064K	H3152 H3064	1 1
SR500×10	42,000	500	10	SD556 SD648	22256K 22348K	H3156 H2348	1 1
SR520×10	43,000	520	10	SD3068	23068K	H3068	1
SR540×10	62,000	540	10	SD560 SD652 SD3072	22260K 22352K 23072K	H3160 H2352 H3072	1 1 1
SR560×10	68,000	560	10	SD3076	23076K	H3076	1
SR580×10	74,000	580	10	SD564 SD656	22264K 22356K	H3164 H2356	1 1